

DATA SHEET

SA58602

High precision operational amplifier

Product data
Supersedes data of 2002 Nov 13

2003 Oct 15

High precision operational amplifier

SA58602

GENERAL DESCRIPTION

The SA58602 is a low voltage, high precision dual operational amplifier. The input offset voltage is typically 100 μV with a very low temperature drift of $\pm 1 \mu\text{V}/^\circ\text{C}$. The SA58602 supply current is typically 100 μA per amplifier, and it operates from 1.8 V to 6 V single supply.

Having single power supply capability, low current consumption, low offset voltage, low input offset current and low input bias current, the SA58602 is ideal for battery powered applications. It is excellent for precision amplifiers in portable instrumentation equipment used for test and measurement, medical monitors and diagnostics, and remote meters and sensors.

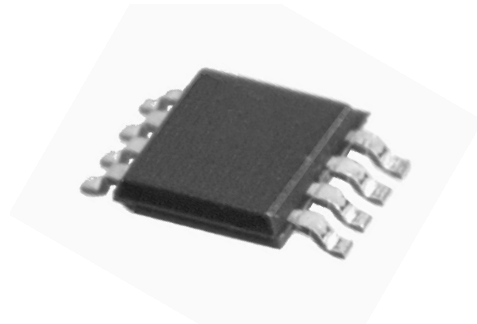

FEATURES

- Functionality to 1.8 V typical
- Low supply current: 100 μA per amplifier (typical)
- Very low input offset voltage: 100 μV (typical)
- Very low input offset drift: $\pm 1 \mu\text{V}/^\circ\text{C}$ (typical)
- Low input offset current: 1 nA (typical)
- Low input bias current: 50 nA (typical)
- Open loop gain: 100 dB (typical)
- Common mode input includes ground

APPLICATIONS

- Signal conditioning and sensing amplification
- Portable instrumentation: Test & measurement, medical monitors and diagnostics, remote meters
- Error amplifiers
- Communications: Pagers, cellular phones, LAN, 5 V datacom bus
- Security systems
- Transducer buffer amplifier

SIMPLIFIED DEVICE DIAGRAM

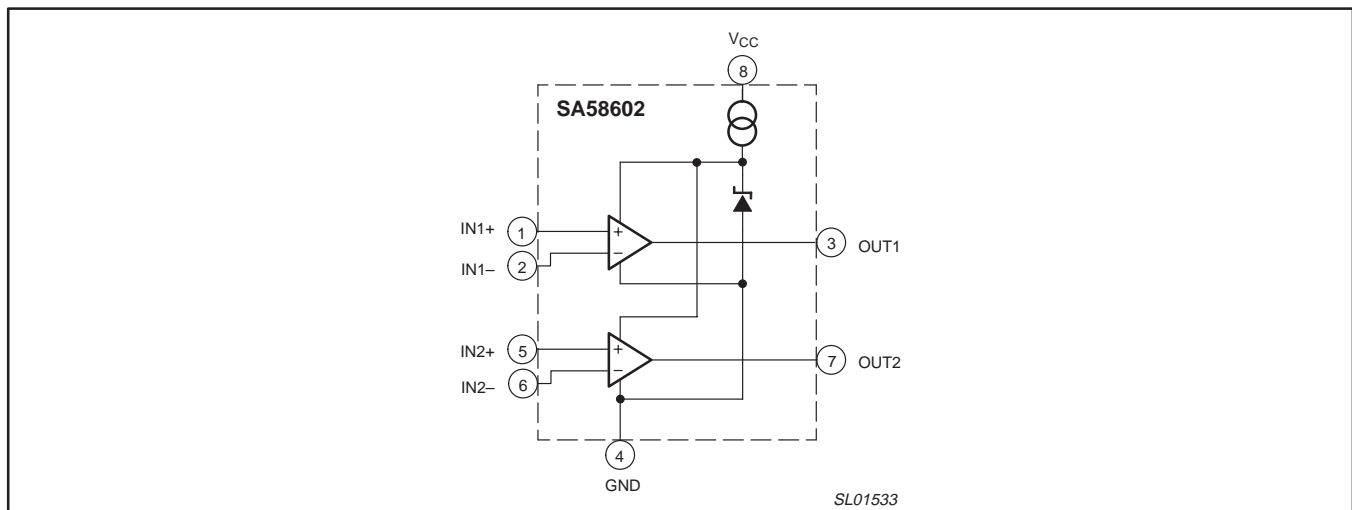

Figure 1. Simplified device diagram.

High precision operational amplifier

SA58602

ORDERING INFORMATION

TYPE NUMBER	PACKAGE			TEMPERATURE RANGE
	NAME	DESCRIPTION	VERSION	
SA58602D	SO8	plastic small outline package; 8 leads; body width 3.9 mm	SOP005	-40 to +85 °C

Part number marking

Each device is marked with three or four lines of alphanumeric codes. The first three letters of the top line designate the product. The fourth letter, represented by 'x', is a date tracking code. The remaining lines of characters are internal manufacturing codes.

Part number	Marking
SA58602D	A G V x

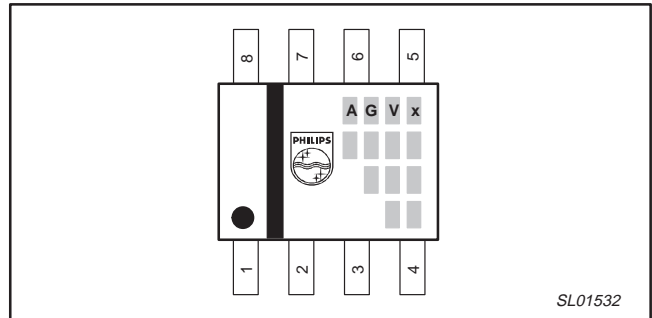

PIN CONFIGURATION

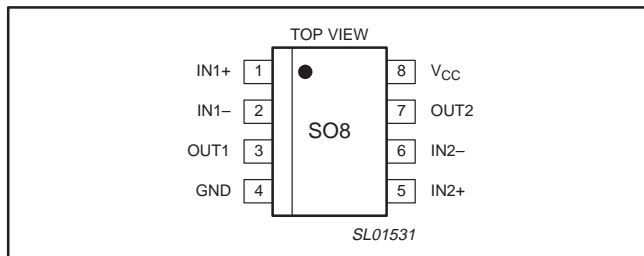

Figure 2. Pin configuration.

PIN DESCRIPTION

PIN	SYMBOL	DESCRIPTION
1	IN1+	Non-inverting input of Amp 1
2	IN1-	Inverting input of Amp 1
3	OUT1	Output of Amp 1
4	GND	Ground
5	IN2+	Non-inverting input of Amp 2
6	IN2-	Inverting input of Amp 2
7	OUT2	Output of Amp 2
8	V _{CC}	Positive supply

MAXIMUM RATINGS

SYMBOL	PARAMETER	MIN.	MAX.	UNIT
V _{CC}	Single supply voltage	-0.3	+10	V
V _{IN}	Input voltage	-0.3	+10	V
T _{stg}	Storage temperature	-40	+125	°C
T _{amb}	Operating temperature	-40	+85	°C
P	Power dissipation	-	300	mW

High precision operational amplifier

SA58602

ELECTRICAL CHARACTERISTICS $V_{CC} = 3.0\text{ V}$, $V_{IN} = 0\text{ V}$, and $T_{amb} = 25\text{ }^{\circ}\text{C}$, unless otherwise specified.

SYMBOL	PARAMETER	CONDITIONS	MIN.	TYP.	MAX.	UNIT
I_{CC}	Supply current		–	0.1	0.15	mA
PSRR	Power supply rejection ratio	$f = 100\text{ Hz}$	50	60	–	dB
V_{CC}	Power supply voltage operating range		1.8	3.0	6.0	V
V_{IN}	Input voltage range		–0.2	–	0.3	V
V_{IO}	Input offset voltage		–	± 0.1	± 0.35	mV
$\Delta V_{IO}/\Delta T$	Input offset voltage temperature drift	$T_{amb} = -20\text{ to }+75\text{ }^{\circ}\text{C}$	–	± 1	± 3	$\mu\text{V}/^{\circ}\text{C}$
I_{IO}	Input offset current		–	1	10	nA
$I_{i(\text{bias})}$	Input bias current		–	50	150	nA
$G_{V(\text{ol})}$	Open-loop voltage gain		80	100	–	dB
I_O	Output current	$V_{IN} = 10\text{ mV}$; $V_O = 0.5\text{ V}$	0.5	–	–	mA
V_O	Output voltage swing	$V_{IN} = -5\text{ to }+25\text{ mV}$; $R_L = 10\text{ k}\Omega$	0.01	–	$V_{CC} - 1.0$	V

High precision operational amplifier

SA58602

TYPICAL CHARACTERIZATION CURVES

Unless otherwise specified, $V_{CC} = 3.0\text{ V}$, $V_{IN} = 0\text{ V}$, and $T_{amb} = 25\text{ }^\circ\text{C}$.

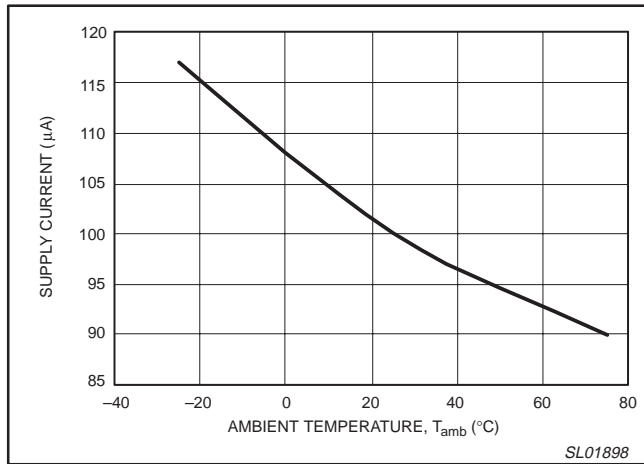

Figure 3. Supply current versus ambient temperature.

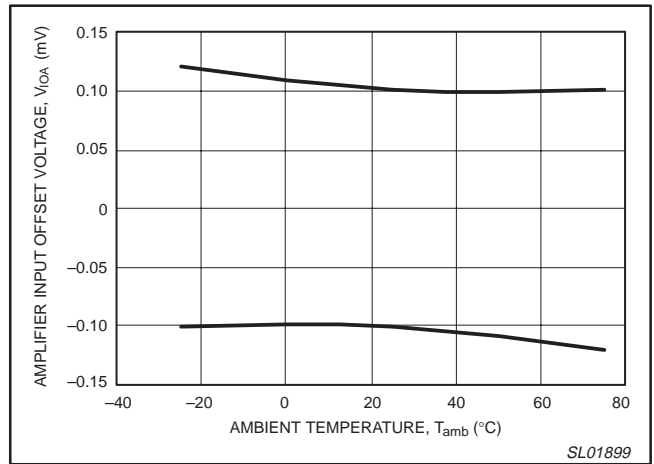

Figure 4. Amplifier input offset voltage versus ambient temperature.

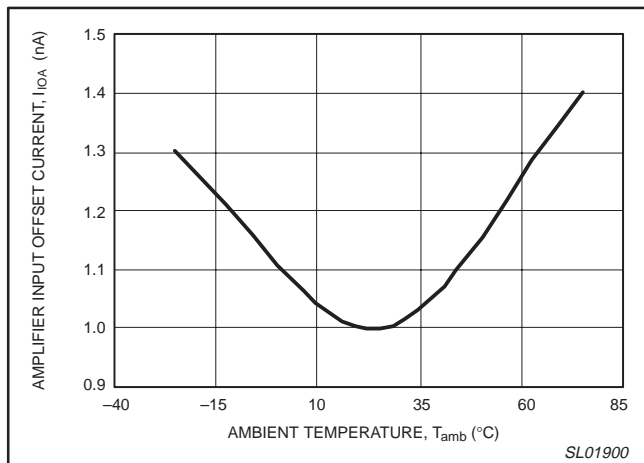

Figure 5. Amplifier input offset current versus ambient temperature.

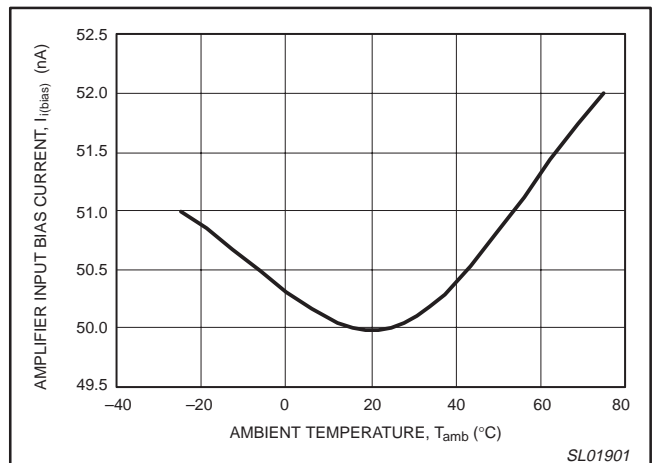

Figure 6. Amplifier input bias current versus ambient temperature.

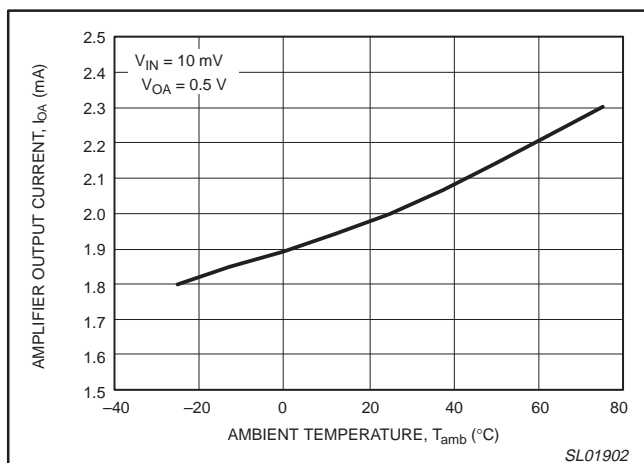

Figure 7. Amplifier output current versus ambient temperature.

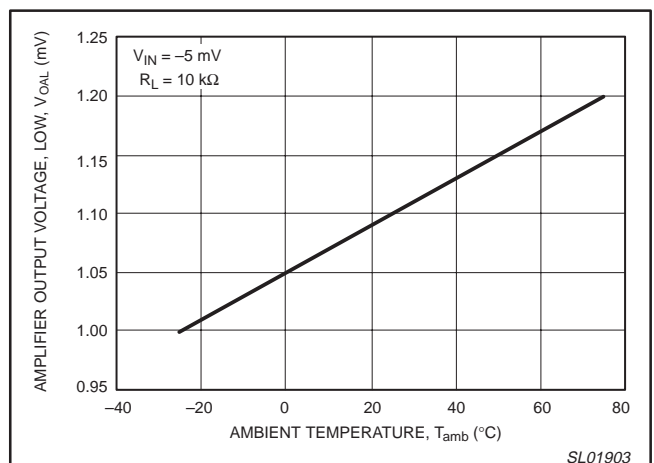

Figure 8. Amplifier output voltage, low versus ambient temperature.

High precision operational amplifier

SA58602

TYPICAL CHARACTERIZATION CURVES (continued)

Unless otherwise specified, $V_{CC} = 3.0\text{ V}$, $V_{IN} = 0\text{ V}$, and $T_{amb} = 25\text{ }^\circ\text{C}$.

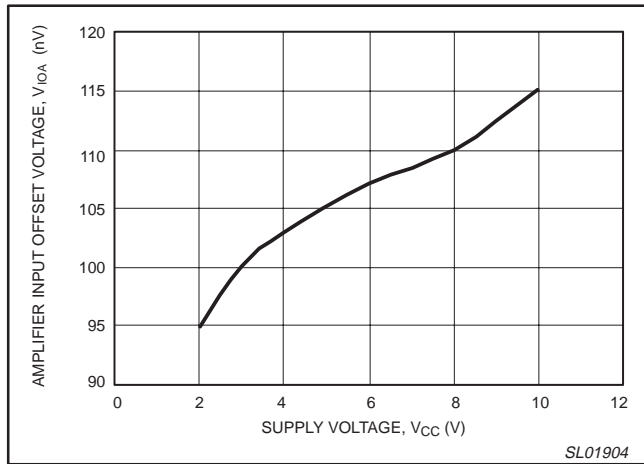

Figure 9. Amplifier offset voltage versus supply voltage.

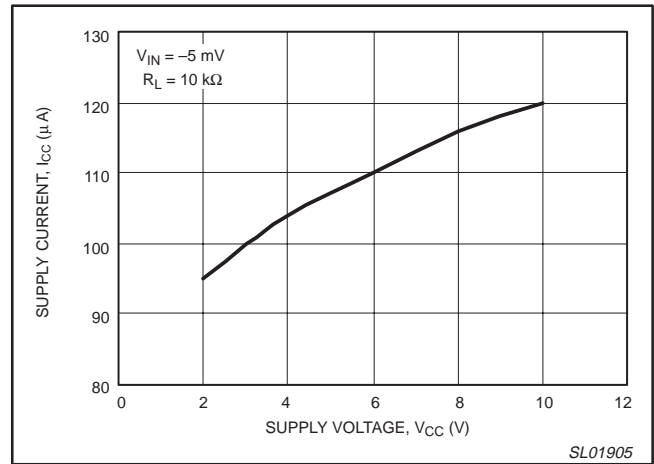

Figure 10. Supply current versus supply voltage.

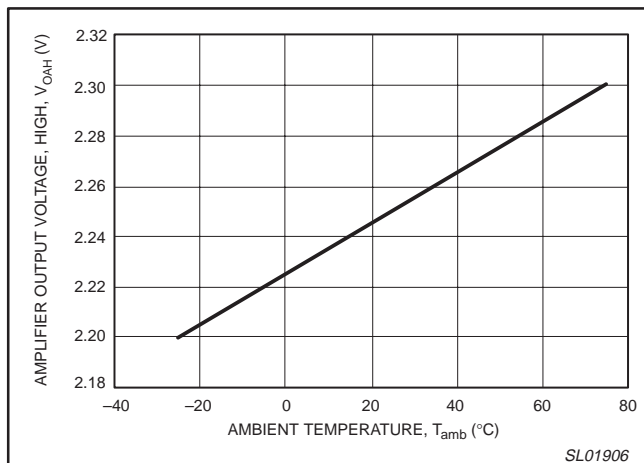

Figure 11. Amplifier input offset current versus supply voltage.

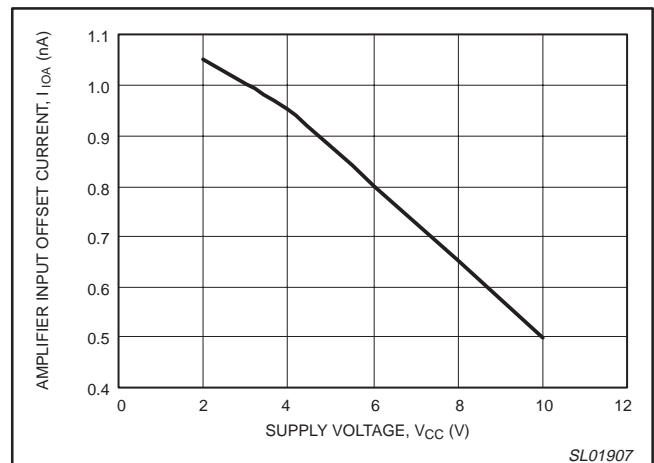

Figure 12. Amplifier input offset current versus supply voltage.

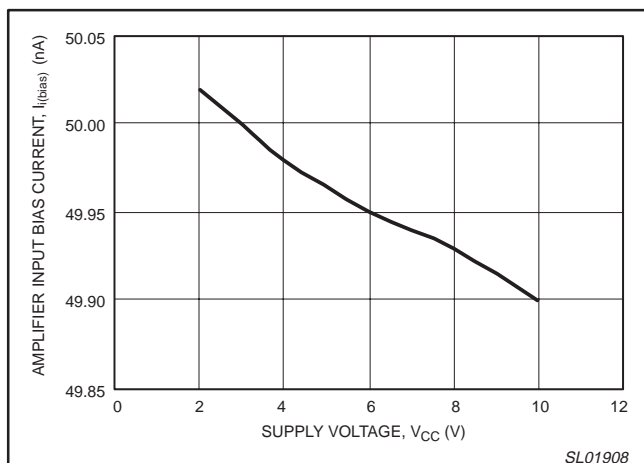

Figure 13. Amplifier input bias current versus supply voltage.

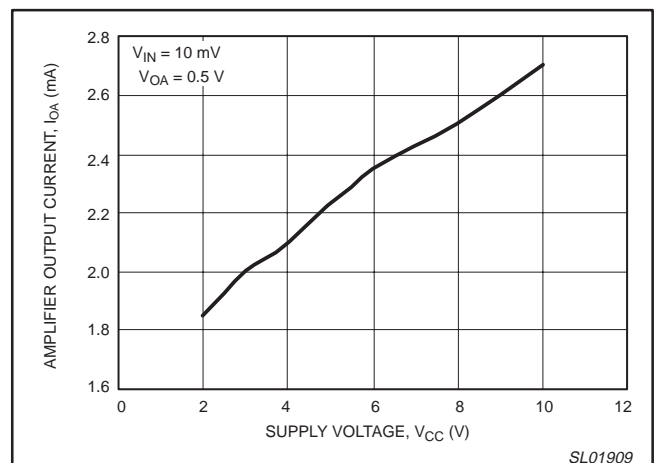

Figure 14. Amplifier output current versus supply voltage.

High precision operational amplifier

SA58602

TYPICAL CHARACTERIZATION CURVES (continued)

Unless otherwise specified, $V_{CC} = 3.0\text{ V}$, $V_{IN} = 0\text{ V}$, and $T_{amb} = 25\text{ }^\circ\text{C}$.

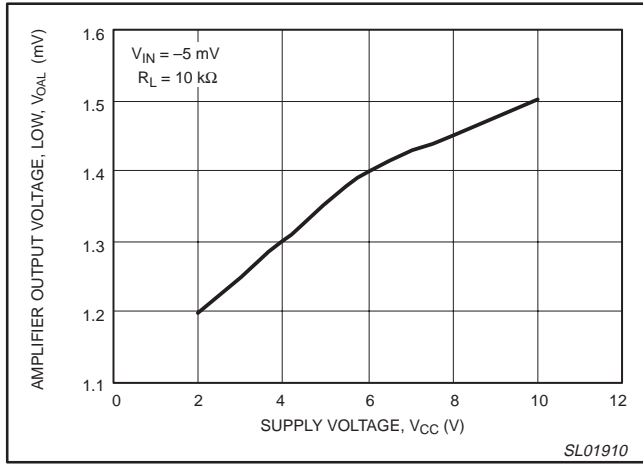

Figure 15. Amplifier output voltage, LOW versus supply voltage.

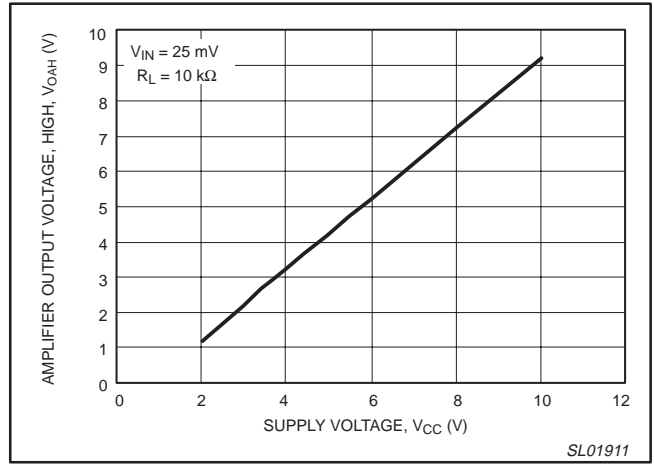

Figure 16. Amplifier output voltage, HIGH versus supply voltage.

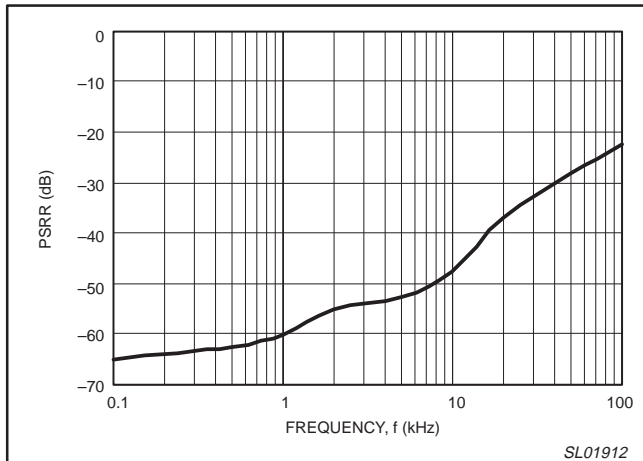

Figure 17. PSRR, power supply rejection ratio versus frequency.

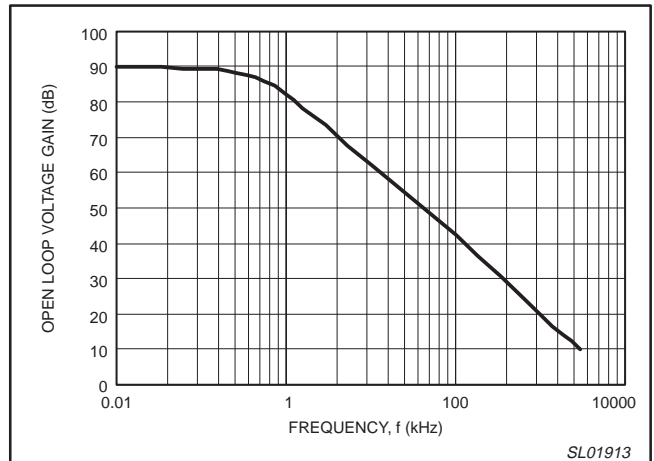

Figure 18. Open loop voltage gain versus frequency.

High precision operational amplifier

SA58602

APPLICATION INFORMATION

The SA58602 is a precision dual op amps with PNP input stages and emitter follower outputs. It may be used as a sensor amplifier with a recommended gain from 20 to 50 dB. It also may be used as a dual comparator with V_{CC} "H" and ground "L" inputs. The output "L" is less than 10 mV and "H" is $V_{CC} - 1 V$.

It operates from 2 to 6 V single supply and each amplifier draws typically 100 μA making it attractive for battery operation. With very low input offset voltage (typically 100 mV), low input offset current (typically 1 nA) and low bias current (typically 50 nA), the SA58602 is ideal for error amplifiers, transducer buffer amplifiers, medical monitors, remote meters, signal conditioning and sensor amplifiers.

Determination of external components

Recommended amplifier gain is 40 dB. The gain is set by the combination of R1, R2, and R3 as shown in the following equations:

$$A_v = (R_3 + R_2) / R_3;$$

$$A_v \text{ (dB)} = 20 \log (A_v); \text{ and } R_3 = R_1 \parallel R_2$$

For a gain of 40 dB, $A_v = 100 V/V$, if $R_2 = 100 \text{ k}\Omega$, then $99 \cdot R_3 = 100 \text{ k}\Omega$; $R_3 = 1.01 \text{ k}\Omega$.

$$R_3 = R_1 \cdot R_2 / (R_1 + R_2); \quad R_3 \cdot R_1 + R_3 \cdot R_2 = R_1 \cdot R_2;$$

$$R_3 \cdot R_2 = R_1 (R_2 - R_3)$$

Thus $R_1 = R_3 \cdot R_2 / (R_2 - R_3) = 1.02 \text{ k}\Omega$.

Comparator Circuit

As shown in Table 1 below, when the non-inverting input, IN+ is pulled "H" (to V_{CC}), and the inverting input, IN- is pulled "L" (to ground), then the output goes "H" ($V_{CC} - 1 V$). Conversely, if the non-inverting input is pulled "L", and the inverting input is pulled HIGH then the output goes "L".

Table 1. Logic table for Amp1 and Amp2

IN+	IN-	OUT	V_{OUT} level
H	L	H	$V_{CC} - 1 V$
L	H	L	10 mV
H	H	H	$V_{CC} - 1 V$
L	L	H	$V_{CC} - 1 V$

Application example

A gas burner flame detection circuit shown in Figure 19 consists of two amplifiers: AMP1 configured as an inverting amplifier and AMP2 configured as a comparator. If S1 selects V_{CC} , the inverting terminal of AMP2 is logic 1 (HIGH). When the flame is ON, the output of AMP1 is HIGH. Thus, the output of AMP2 is HIGH. Conversely, when the flame is OFF, AMP2 output is LOW.

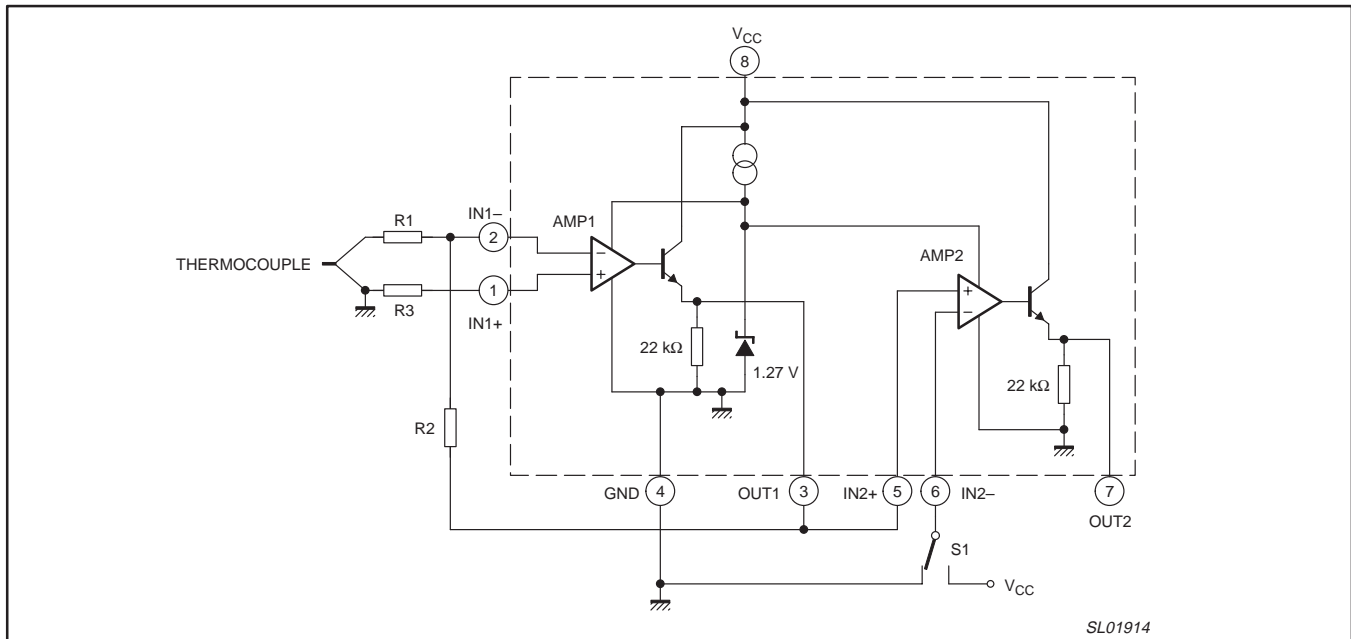

Figure 19. SA58602 gas burner flame detection circuit.

High precision operational amplifier

SA58602

PACKING METHOD

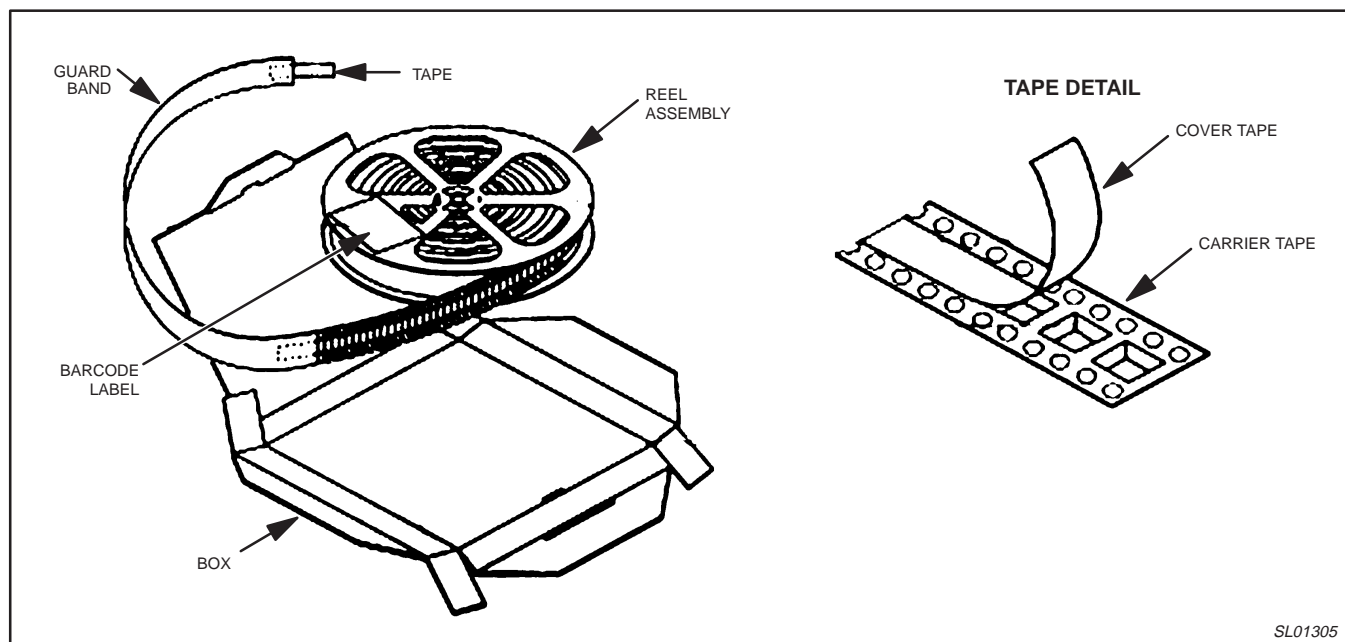

Figure 20. Tape and reel packing method.

SL01305

High precision operational amplifier

SA58602

S08: plastic small outline package; 8 leads; body width 3.9 mm

SOP005

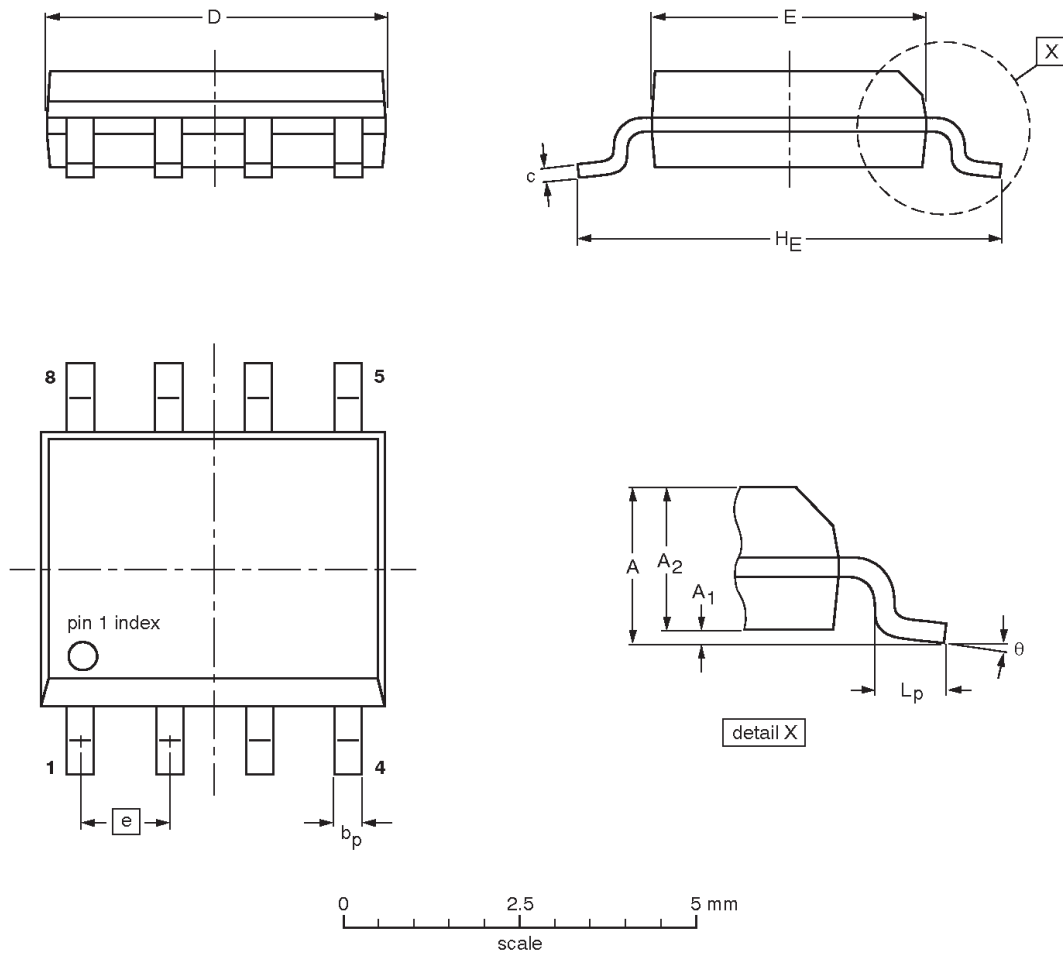

DIMENSIONS (inch dimensions are derived from the original mm dimensions)

UNIT	A max.	A ₁	A ₂	b _p	c	D ⁽¹⁾	E ⁽²⁾	e	H _E	L _p	θ
mm	1.73	0.25 0.10	1.45 1.25	0.51 0.33	0.25 0.19	4.95 4.80	4.0 3.8	1.27	6.2 5.8	1.27 0.38	8° 0°
inches	0.068	0.010 0.004	0.057 0.049	0.013 0.020	0.0100 0.0075	0.20 0.19	0.16 0.15	0.050	0.244 0.228	0.050 0.015	

Notes

1. Plastic or metal protrusions of 0.15 mm maximum per side are not included.
2. Plastic or metal protrusions of 0.25 mm maximum per side are not included.

OUTLINE VERSION	REFERENCES				EUROPEAN PROJECTION	ISSUE DATE
	IEC	JEDEC	JEITA			
SOP005	076E03	MS-012				03-10-07

High precision operational amplifier

SA58602

REVISION HISTORY

Rev	Date	Description
_3	20031015	Product data (9397 750 12183). ECN 853–2288 30321 dated 09 September 2003. Supersedes data of 2002 Nov 13 (9397 750 10648). Modifications: <ul style="list-style-type: none">• Change package outline version to SOP005 in Ordering information table and Package outline sections.
_2	20021113	Product data (9397 750 10648). ECN 853–2288 29133 dated 31 October 2002. Supersedes data of 2001 Oct 03 (9397 750 08954).
_1	20011003	Product data; initial version (9397 750 08954). ECN 853–2288 27197 dated 03 October 2001.

High precision operational amplifier

SA58602

Data sheet status

Level	Data sheet status ^[1]	Product status ^{[2] [3]}	Definitions
I	Objective data	Development	This data sheet contains data from the objective specification for product development. Philips Semiconductors reserves the right to change the specification in any manner without notice.
II	Preliminary data	Qualification	This data sheet contains data from the preliminary specification. Supplementary data will be published at a later date. Philips Semiconductors reserves the right to change the specification without notice, in order to improve the design and supply the best possible product.
III	Product data	Production	This data sheet contains data from the product specification. Philips Semiconductors reserves the right to make changes at any time in order to improve the design, manufacturing and supply. Relevant changes will be communicated via a Customer Product/Process Change Notification (CPCN).

[1] Please consult the most recently issued data sheet before initiating or completing a design.

[2] The product status of the device(s) described in this data sheet may have changed since this data sheet was published. The latest information is available on the Internet at URL <http://www.semiconductors.philips.com>.

[3] For data sheets describing multiple type numbers, the highest-level product status determines the data sheet status.

Definitions

Short-form specification — The data in a short-form specification is extracted from a full data sheet with the same type number and title. For detailed information see the relevant data sheet or data handbook.

Limiting values definition — Limiting values given are in accordance with the Absolute Maximum Rating System (IEC 60134). Stress above one or more of the limiting values may cause permanent damage to the device. These are stress ratings only and operation of the device at these or at any other conditions above those given in the Characteristics sections of the specification is not implied. Exposure to limiting values for extended periods may affect device reliability.

Application information — Applications that are described herein for any of these products are for illustrative purposes only. Philips Semiconductors make no representation or warranty that such applications will be suitable for the specified use without further testing or modification.

Disclaimers

Life support — These products are not designed for use in life support appliances, devices, or systems where malfunction of these products can reasonably be expected to result in personal injury. Philips Semiconductors customers using or selling these products for use in such applications do so at their own risk and agree to fully indemnify Philips Semiconductors for any damages resulting from such application.

Right to make changes — Philips Semiconductors reserves the right to make changes in the products—including circuits, standard cells, and/or software—described or contained herein in order to improve design and/or performance. When the product is in full production (status 'Production'), relevant changes will be communicated via a Customer Product/Process Change Notification (CPCN). Philips Semiconductors assumes no responsibility or liability for the use of any of these products, conveys no license or title under any patent, copyright, or mask work right to these products, and makes no representations or warranties that these products are free from patent, copyright, or mask work right infringement, unless otherwise specified.

Contact information

For additional information please visit
<http://www.semiconductors.philips.com>. Fax: +31 40 27 24825

© Koninklijke Philips Electronics N.V. 2003
 All rights reserved. Printed in U.S.A.

Date of release: 10-03

For sales offices addresses send e-mail to:
sales.addresses@www.semiconductors.philips.com

Document order number:

9397 750 12183

Let's make things better.